

# Eclipse Single-Ended Ceramic Radiant Tube Burners

Model SER 450

Version 5

Parameter	Typical Burner Input 1000's BTU/hr (kW)			
	50 (14,6)	75 (21,9)	100 (29,3)	
<b>Low firing rate, 1000's BTU/hr (kW)<sup>1</sup></b> <i>Between 150 - 220% excess air</i>	10 (3,0)	10 (3,0)	10 (3,0)	
<b>Total static air pressure required, "w.c. (mbar)<sup>2</sup></b> <i>(509mm recuperator length)</i>	9.7 (24,2)	15.6 (39)	18.5 (46,3)	
<b>Air flow, SCFH (Nm<sup>3</sup>/hr)</b> <i>At 15% excess air</i>	560 (15,0)	840 (22,5)	1120 (30,0)	
<b>Gas Inlet Pressure Required, "w.c. (mbar)<sup>3</sup></b> <i>Tap B (see page 4)</i>	Natural Gas	7.8 (19,4)	13 (32,4)	14 (34,9)
	Propane	7.8 (19,4)	16.8 (41,8)	19.7 (49,1)
	Butane	6.3 (15,7)	13.7 (34,1)	16.0 (39,9)
<b>Maximum Furnace Temperature</b> <i>Refer to page 3 for maximum heat flux</i>	2300°F (1260°C) with Natural Gas 1800°F (982°C) with Propane or Butane			
<b>Piping</b>	NPT or BSP interface is available.			
<b>Flame detection<sup>4</sup></b>	UV Scanner	Natural Gas Only		
	Flame Rod	Natural Gas, Propane, Butane <i>(at or below 1800°F (982°C) furnace temperature)</i>		
<b>Ignition</b>	Direct Spark Ignition (6 kVAC)			
<b>Fuels</b> <i>For any other mixed gas, contact Eclipse</i>	Natural Gas, Propane, or Butane			
<b>Weight, lbs (kg)<sup>5</sup></b> <i>Burner Length "M" (less mounting extension, inner and outer tubes)</i>	36 (16,5)			
<b>Approvals</b>	 <small>API 30</small>			

<sup>1</sup> The low fire rate represents the capability of the burner. Achievement of this rate will be affected by the control method and ratio regulator used in the system design. Typical ratio regulators provide a 10 to 1 turndown from high to low fire.

<sup>2</sup> Air supply pressure required at the burner inlet is static pressure at Tap C plus the pressure drop across Tap A to Tap C. See graphs on page 2.

<sup>3</sup> If a ratio regulator is being used, the gas pressure into the ratio regulator should be at least 5" w.c. above the static air pressure at Tap A.

<sup>4</sup> Flame rod available for furnace temperature up to 1800°F (982°C). Please select UV or contact Eclipse for furnace temperatures in excess of 1800°F (982°C).

<sup>5</sup> All weights are approximate.

- All information is based on laboratory testing with neutral (0.0" w.c.) exhaust conditions.
- All inputs based upon gross calorific values and standard conditions: 1 atmosphere, 70°F (21°C).
- Air and fuel pressure data given in this document are based on 15% excess air and hot furnace conditions.
- Plumbing of gas will affect accuracy of orifice readings. All information based on general acceptable air and gas piping practices.
- Eclipse reserves the right to change the construction and/or configuration of our products at any time without being obliged to adjust earlier supplies accordingly.

# Performance Graphs

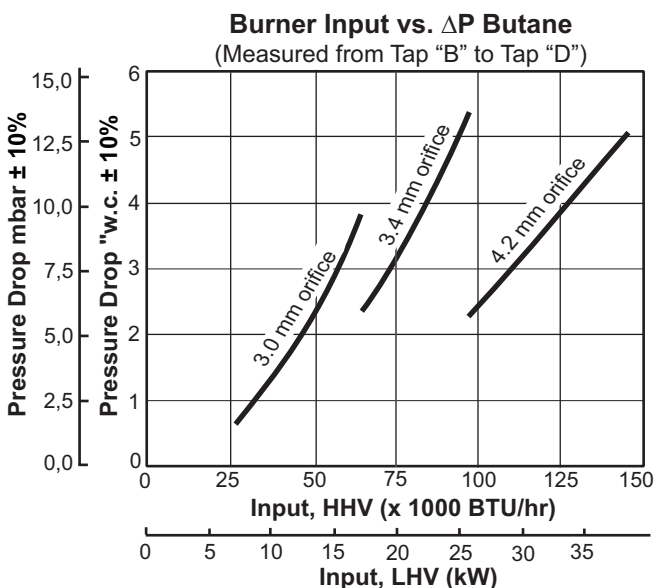
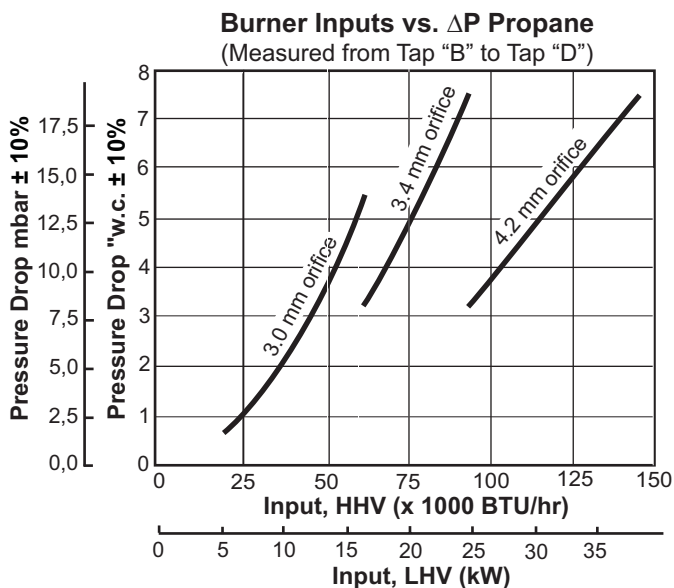
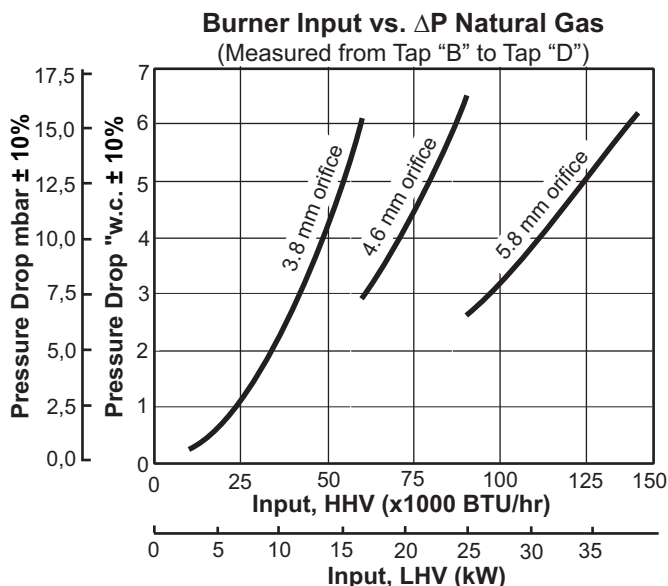
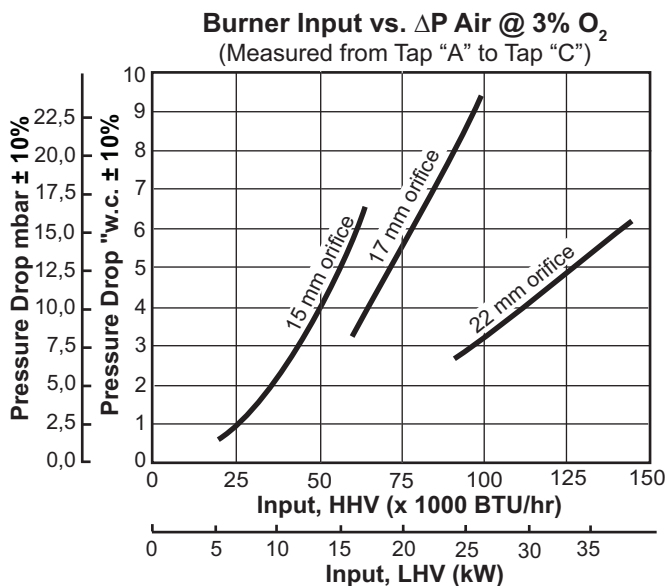
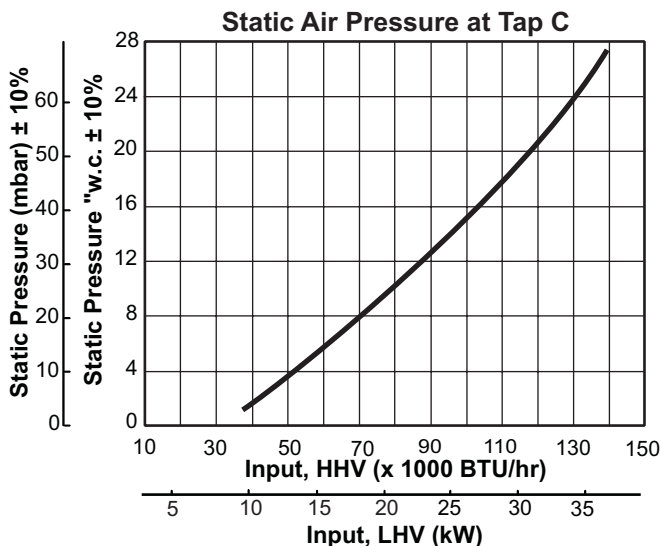
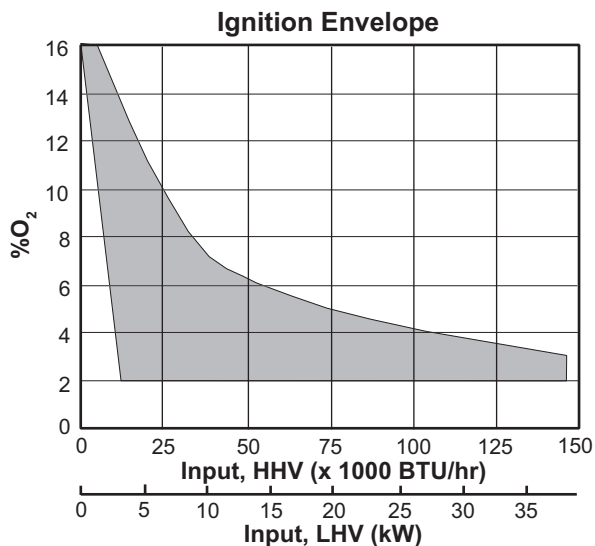

## Efficiency Graphs

Medium Burner (509 mm)

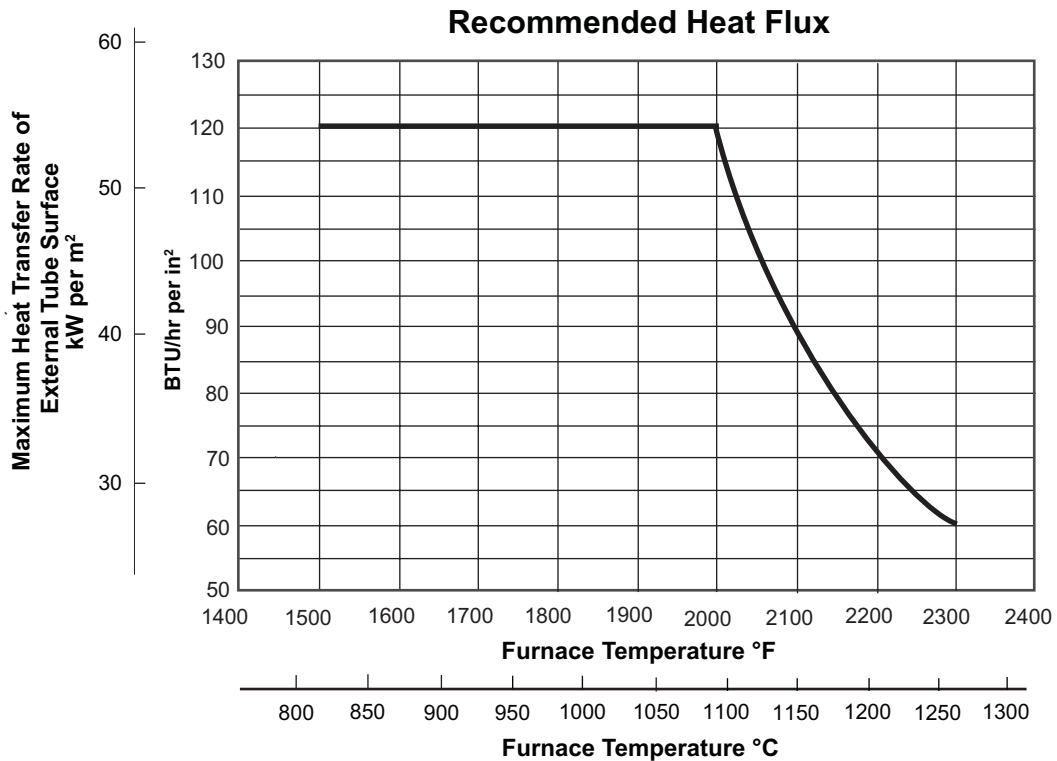
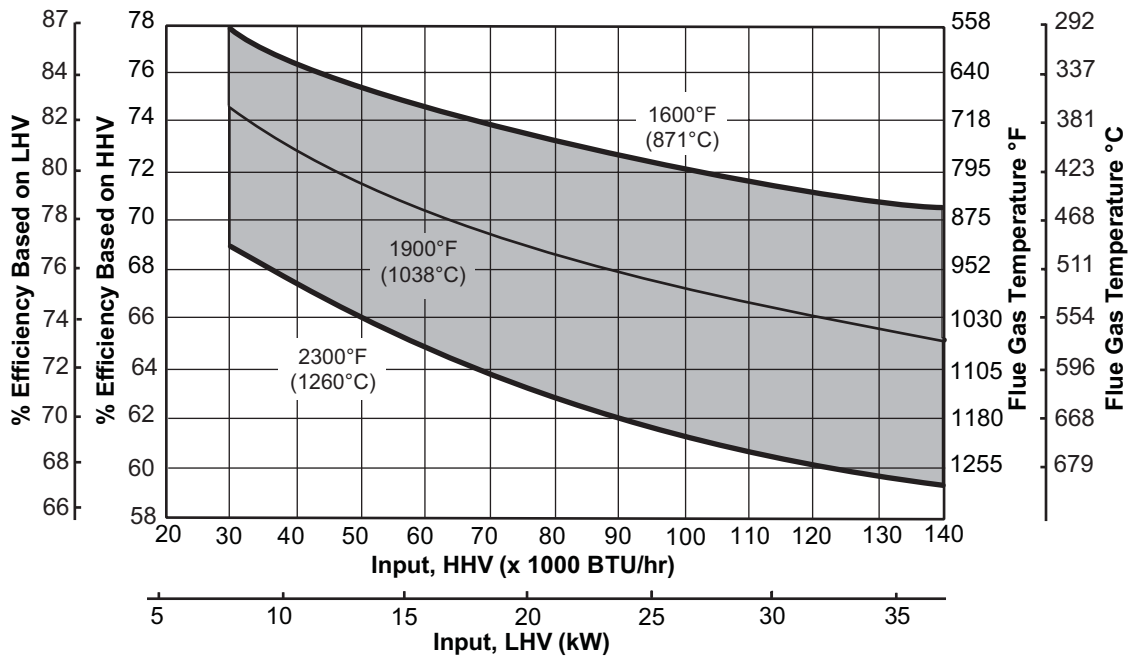

# Horizontally Mounted Burner

## Dimensions & Specifications

Dimensions in mm (inches)

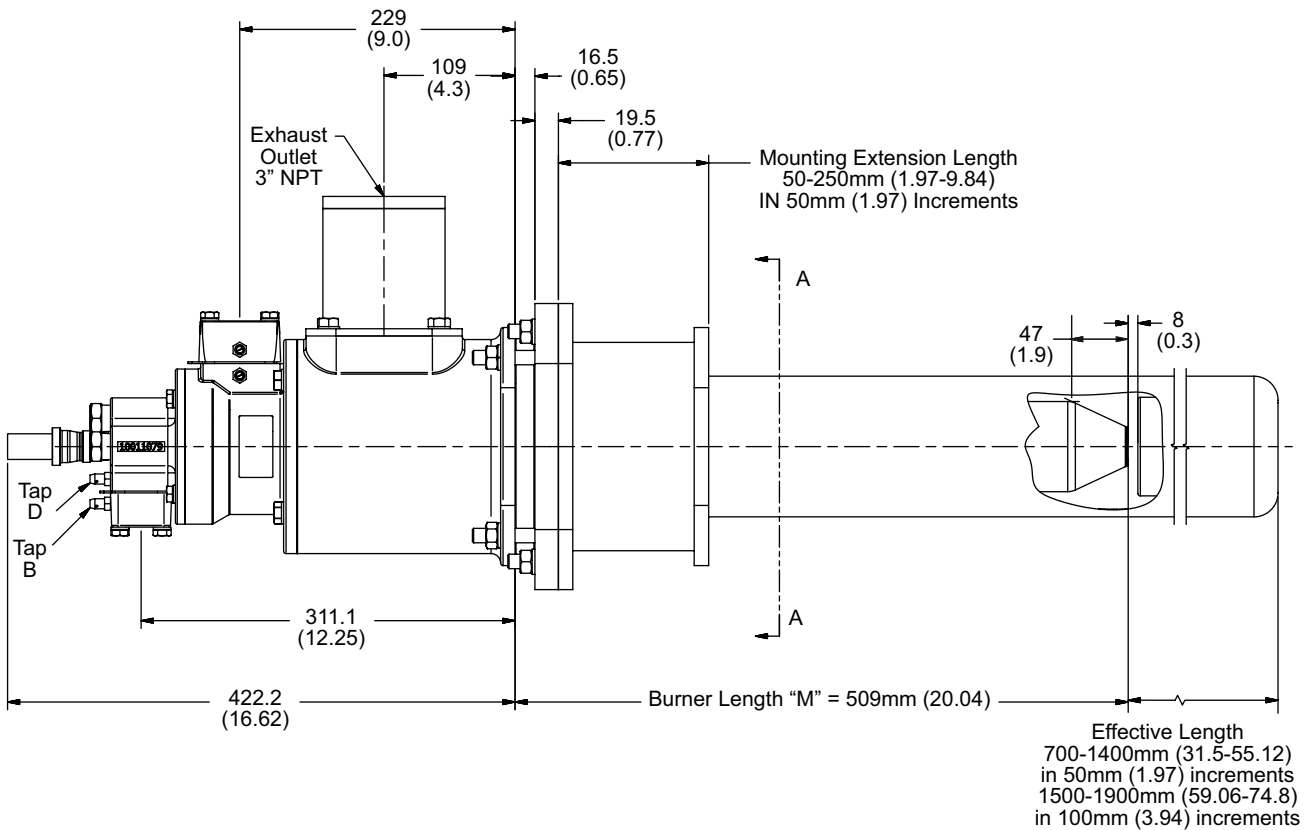
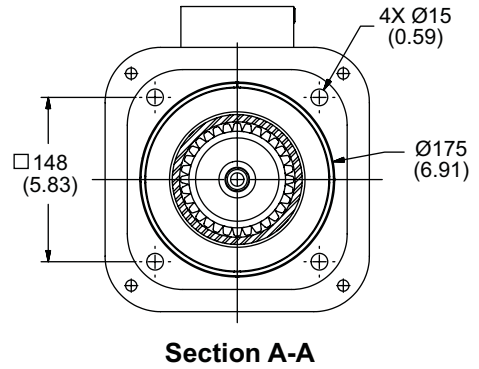
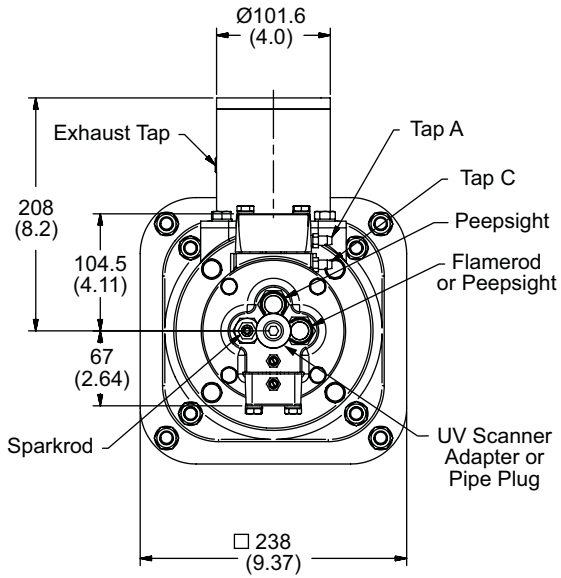

# Vertically Mounted Burner

## Dimensions & Specifications

Dimensions in mm (inches)

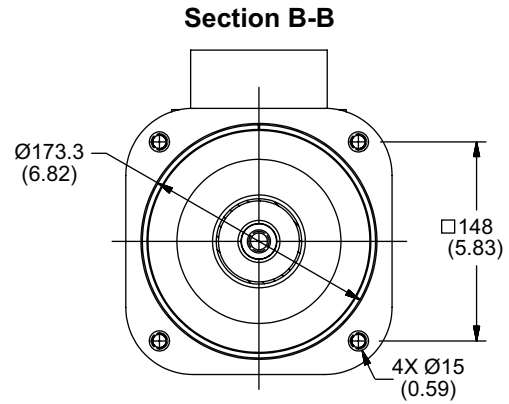
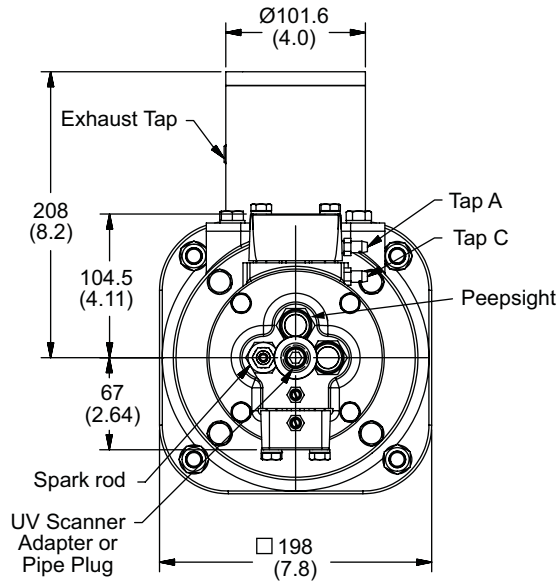

### Vertically Mounted Outer Tube Option

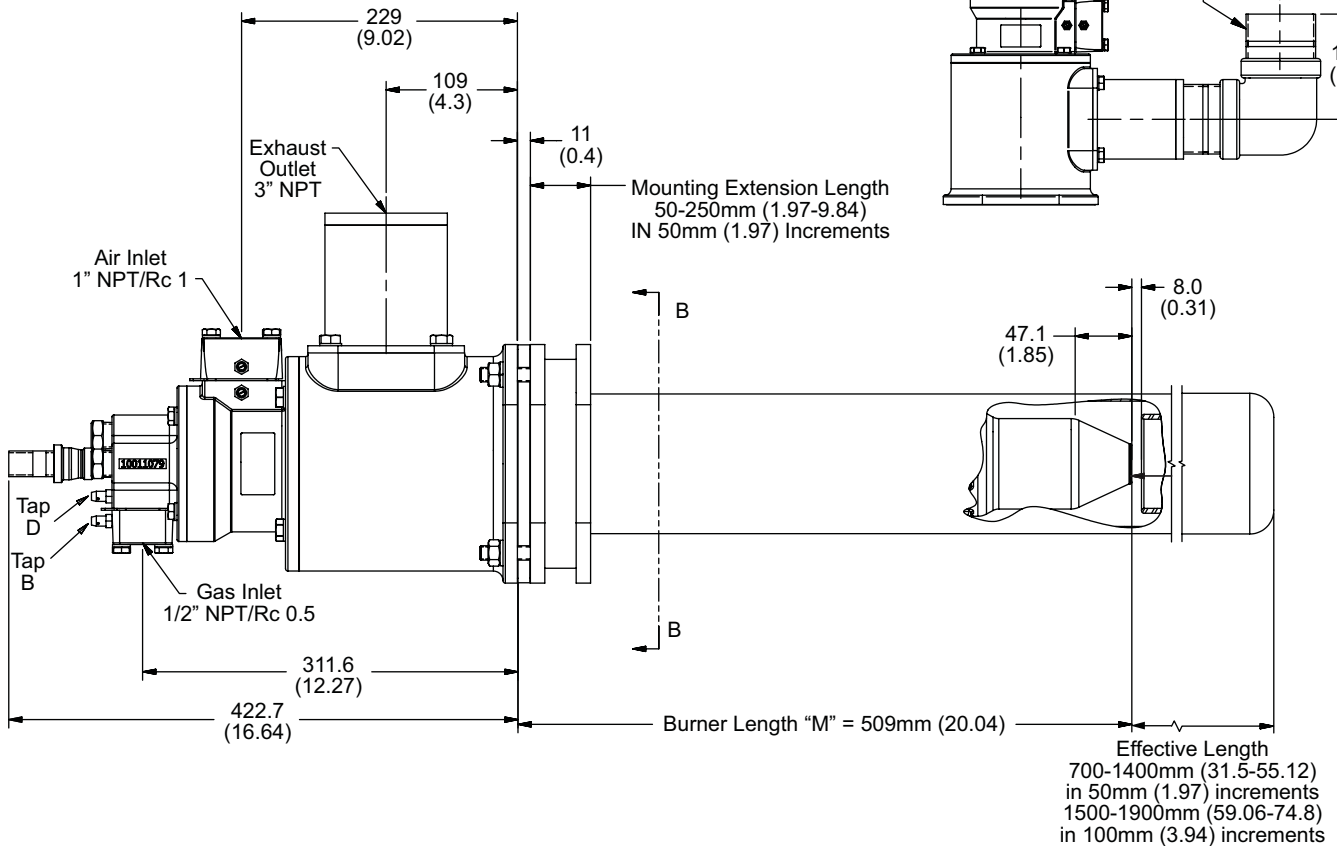
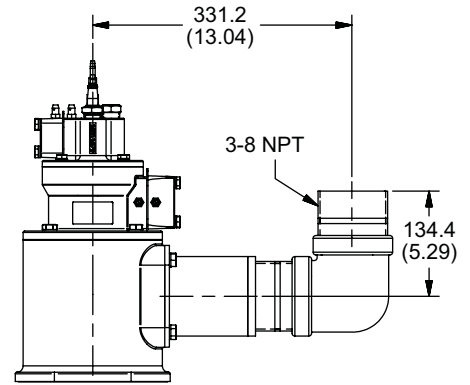



**Offered By:**

Power Equipment Company  
2011 Williamsburg Road  
Richmond, Virginia 23231  
Phone (804) 236-3800  
Fax (804) 236-3882

---

[www.peconet.com](http://www.peconet.com)